

# BIO-FIGHTER® AQUA-SEAL

## Features

- Water-resistant for damp locations
- Internal or external mount
- Multi-voltage electronic ballast
- Remote-mount lamp design
- 6-ft lamp cables
- Single and dual lamp models
- 14" and 16" lamp lengths
- AHU viewport
- ETL safety agency listing to UL 1598
- Limited lifetime warranty



Compact size, 6-ft. lamp cords, and water-resistant design make the Aqua-Seal one of the most versatile UV products on the market today. In tight closet applications, the small footprint of the Aqua-Seal allows the chassis to be mounted to the wall or ceiling, while the remote UV lamps are mounted to the air handling unit. And for even tighter spaces, the water-resistant Aqua-Seal can be mounted completely inside the air handler.



Water-resistant design and components enable the unit to be installed where ordinary systems can't go.

Innovative lamp bracket makes it easy to install the entire Aqua-Seal unit inside the air handling unit.

For maximum water and corrosion resistance, each lamp uses factory-sealed electrical connections

Smart ballast technology senses input voltage and automatically adjusts for 120V to 240V power.

Quick-disconnect lamp cord makes lamp replacement simple while maintaining a water-resistant seal.

An air handler viewport is included. Making it easy to monitor lamp operation in every application.



# BIO-FIGHTER® AQUA-SEAL

Germicidal Ultraviolet Light

## Specifications

The Bio-Fighter® Aqua-Seal assists in preventing the growth of micro-organism contaminants in the HVAC system. To ensure maximum effectiveness, install and maintain the Bio-Fighter® in accordance with installation and maintenance instructions.

**Dimensions:** See Fig.1

**Electrical:**

The Aqua-Seal uses a multi-input voltage electronic ballast able to operate within a range of 120 to 240 volts.

Power Ratings: 120V - 240V, 50/60 Hz.

**Temperature:**

45° F - 150° F (Outside of duct).

**Lamp:**

9000 hour lamp life. Ozone-producing lamps available as an option.

**Listings:**

ETL Safety Agency - File # 2002554

FIFRA - File #73316

### Sizing

Single and dual lamp models available. For optimum results and maximum UV-C output, dual lamp units are recommended for A-coil and return air applications.

### Installation

The Bio-Fighter® Aqua-Seal remote-mount UV-C lamp system can be mounted anywhere in the HVAC system or ductwork. The preferred installation location is near the cooling coil.

Fig. 1 Dimensions of single and dual bulb Aqua-Seals.

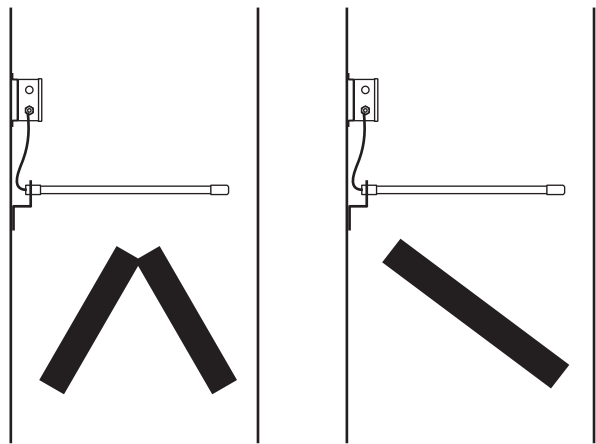
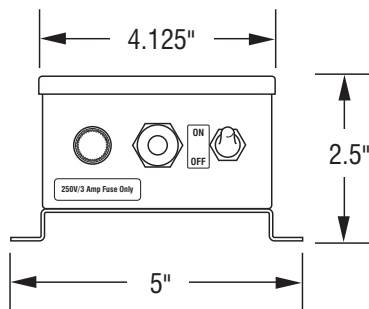
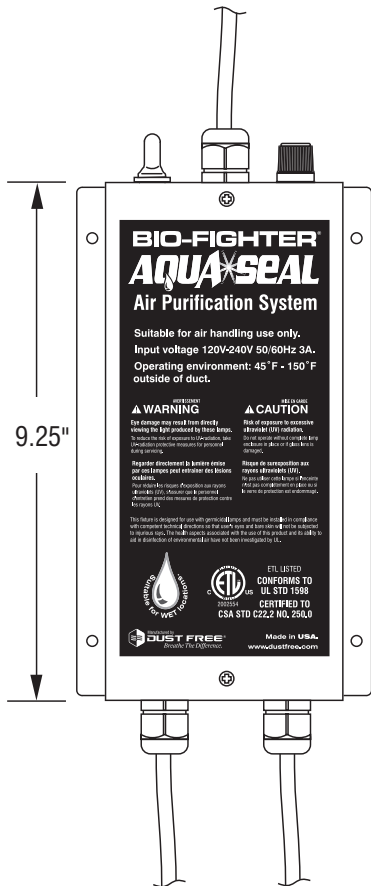

Water-resistant Aqua-Seal mounted inside air handler using included lamp bracket.

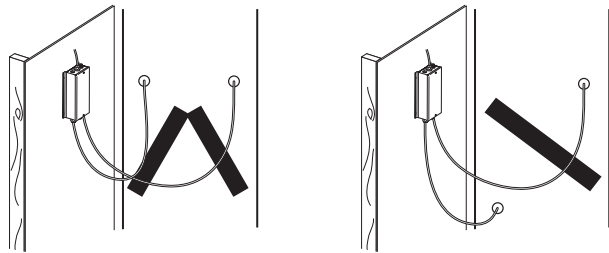

Aqua-Seal mounted on wall near air handler. Remote lamp cords allow the Aqua-Seal to be mounted anywhere within 6 feet of the air handling unit.



PO Box 519 • Royse City, TX 75189  
**1-800-441-1107**  
[Http://www.dustfree.com](http://www.dustfree.com)